

**NEW!**

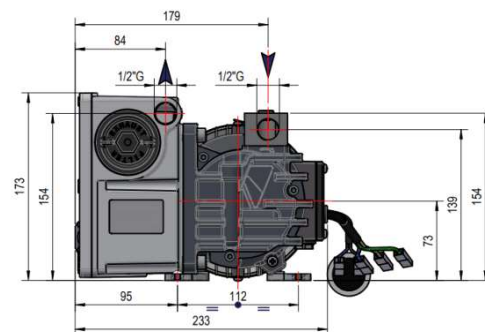
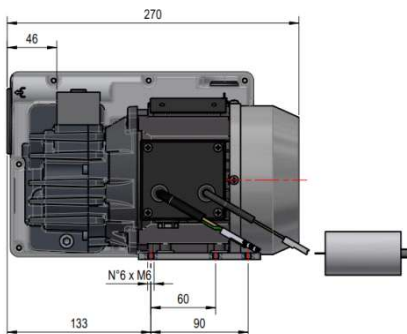

Main Accessories	MD 10
Minor Spare Part Kit	K9601075
Major Spare Part Kit	K9601075/1
Inlet Filter	9001010

### PRODUCT DESCRIPTION:

The **MD 10** oil-lubricated rotary vane vacuum pump is designed to ensure operational reliability, compactness, and easy integration into industrial applications.

### MD 10 series advantages:

- The new die-cast aluminum oil tank improves heat dissipation, reduces overall weight, and ensures a strong and durable structure over time.
- The design has been completely updated to optimize internal accessibility, making cleaning and routine maintenance faster and easier. The pump configuration also allows for multiple customization options to meet specific application requirements.
- Thanks to the oil-lubricated rotary vane technology, the MD 10 ensures continuous operation with stable performance, making it suitable for processes requiring reliability and continuous duty.
- Custom configurations for oil filling and draining positions are available.

### Standard equipment:

- Inlet filters for protection against solid particles
- Specific oils for vacuum pumps
- Routine maintenance kits
- 

### MAIN APPLICATION FIELDS:

Food packaging (vacuum machines, tray sealers, tumblers)  
Automatic packaging machines, Filling and closing systems, OEM applications with on-board machine integration, Industrial processes requiring continuous and stable vacuum, Handling and evacuation of small volumes

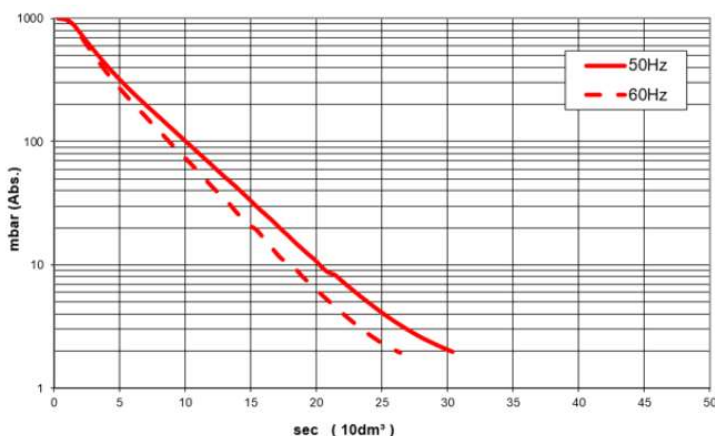
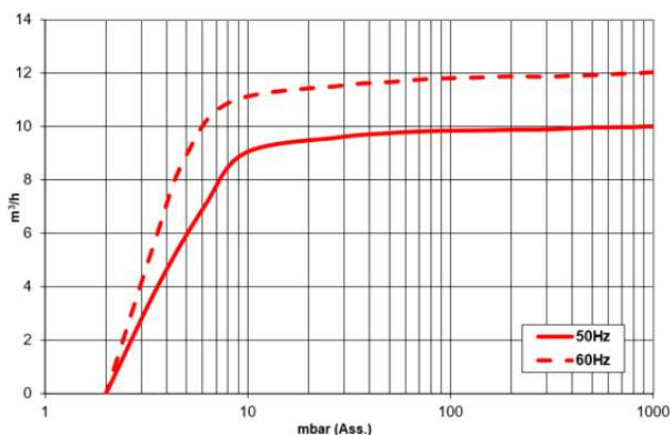

	MD 10	
Part Number	9601075/MX	9601075/TN
Voltage	110-115	175-300/300-520
Nominal Capacity	7.05 CFM	
Total Final Pressure (Abs.)	29.89 inHg / 1.5 Torr	
Motor Power	.6 HP	
Nominal r.p.m.	3300	
Noise Level dB(A)	62	
Weight	31.9 Lbs.	
Oil Type	SW 40	
Oil Quantity	.4 Liters	
Max Inlet Air Temperature	104°F	
Dimensions	106.3" X 91.73" X 68.11"	

Please contact the Manufacturer if environmental conditions are different from those prescribed.